

Continuous Motion Equipment

Rotary Case Packers and Uncasers



*Quiet, Smooth,
and Gentle
Handling
of
Containers*

Speeds up to 60 CPM

Equipment Capacity

4-heads = 20 CPM

6-heads = 30 CPM

9-heads = 45 CPM

12-heads = 60 CPM



(513) 874-1233

Fax: (513) 874-3375

25 Standen Drive Hamilton, OH 45015

email: info@climaxpackaging.com

- PLC controls
- Wide variety of pick up devices
- Soft, gentle handling of containers

CLIMAX
PACKAGING MACHINERY

CLIMAX CONTINUOUS PACKER - 9 HEADS

REVERSE - INLINE DESIGN

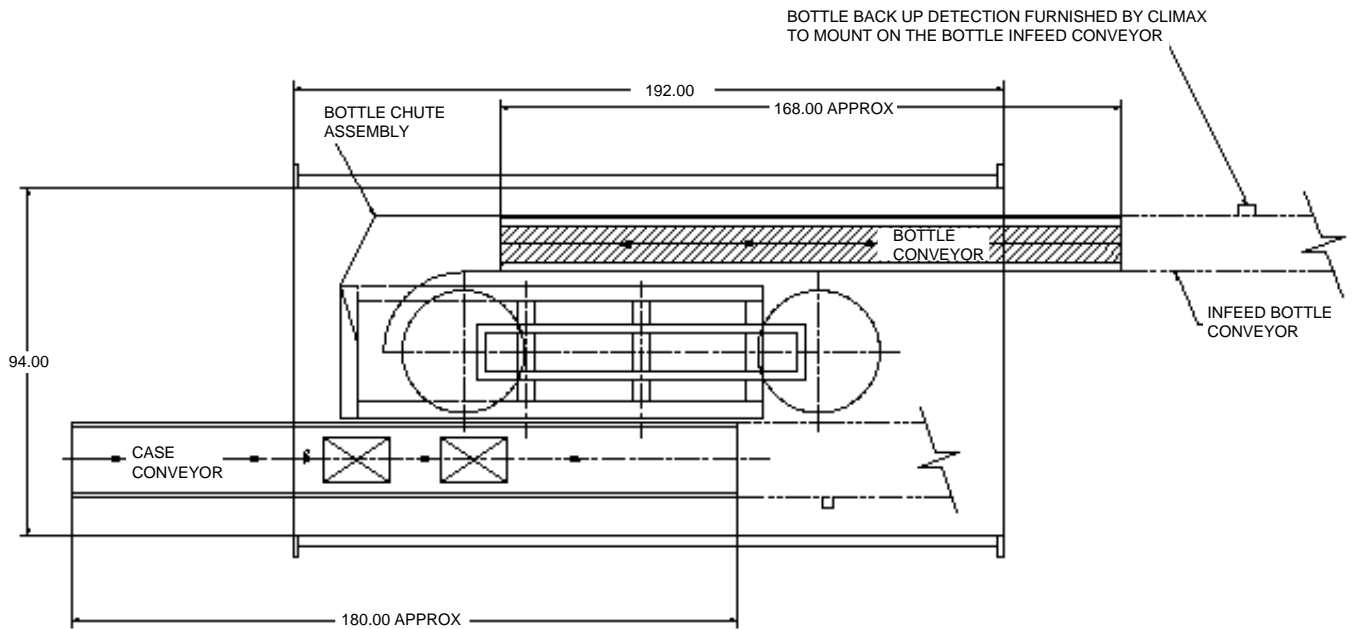

CLIMAX CONTINUOUS UNCASER - 9 HEADS

INLINE DESIGN

