

Climax Mass Airflow SOFT Packer

SOFT Packing into BULK Cases or Service Cartons

Specifications

ELECTRICAL

Motors -- 230/460 Volts, 60 HZ, 3 Phase

Controls -- 115 Volts, 60 HZ, 1 Phase

PNEUMATICS

Minimum air supply required = 60 PSI

Air consumption = .05 CFM per cycle

CONVEYOR DRIVES

Container Conveyor -- 0.5 HP fixed speed

Case Conveyor -- 0.5 HP fixed speed

FAN SPECS AND DRIVE

*Dependent upon case dimensions
and bottle pack patterns*

-- contact Climax factory

OPTIMUM CASE SIZE RANGE

Length 20" to 32"

Width 16" to 24"

Height (score) 16" to 24"

*-- For your case sizes,
contact Climax factory*

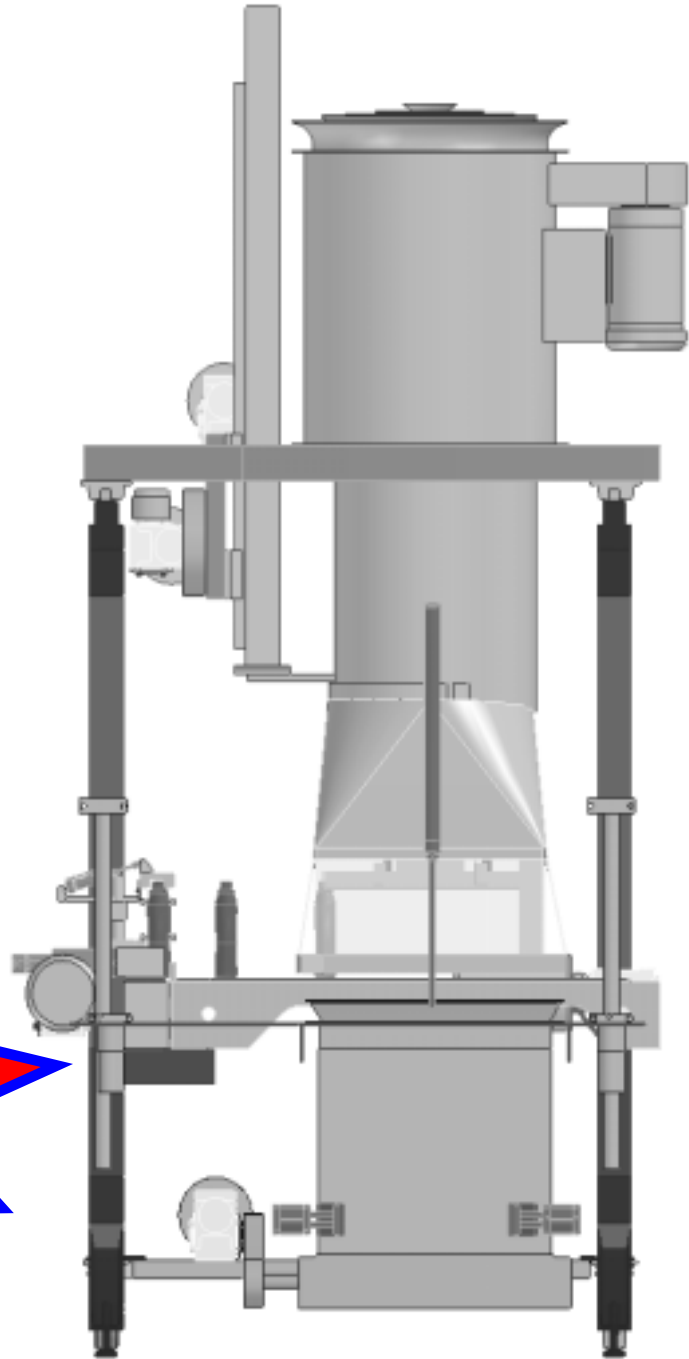

NEW

CLIMAX
PACKAGING MACHINERY

(513) 874-1233 FAX: (513) 874-3375

Email: info@climaxpackaging.com

25 Standen Drive Hamilton, OH 45015

Mass Airflow SOFT Packer

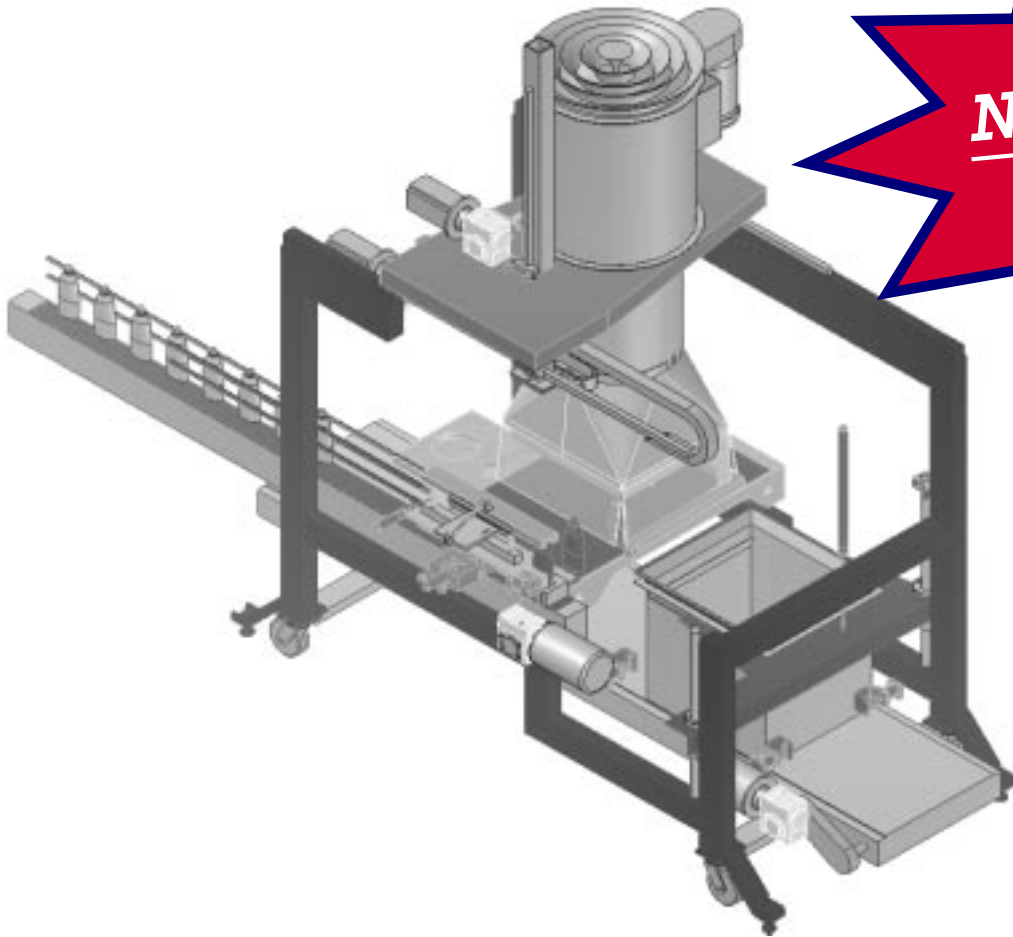

NO Change
Parts

The Airflow Series of SOFT Packers is designed to be a simple, compact, durable, and economic solution for packing empty plastic containers into a large corrugated case.

With a SINGLE airflow bonnet this equipment can pack multiple sizes of bottles and pack patterns into a SINGLE case.

This eliminates multiple sets of change parts

- Fully automatic
- EMPTY plastic containers -- round or non-round
- Single or multiple layers of containers
- Cases with a bag inserted in the case
- PLC Controls
- SERVO drive for the vertical packing motions
- SERVO or A/C motor drive for the horizontal motions
- Casters for mobility and leveling pads for floor mounting



Phone: (513) 874-1233 Fax: (513) 874-3375
25 Standen Drive Hamilton, OH 45015
email: info@climaxpackaging.com

CLIMAX
PACKAGING MACHINERY